

1995-13 Gibraltar Merchant Shipping (Safety, etc.)

Subsidiary Legislation made under s.118.

Gibraltar Merchant Shipping (Stability Requirements for Ro-Ro Passenger Ships) Regulations 2006

LN.2006/022

Commencement (LN.2006/037) **6.4.2006**

Amending enactments	Relevant current provisions	Commencement date
LN. 2020/387	rr. 2, 3(a), 6(1)-(3), 7(3)	1.1.2021

Transposing:
Directive 2003/25/EC

1995-13 Gibraltar Merchant Shipping (Safety, etc.)
2006/022 Gibraltar Merchant Shipping (Stability Requirements for
Ro-Ro Passenger Ships) Regulations 2006

ARRANGEMENT OF REGULATIONS

Regulation

1. Title and commencement.
2. Interpretation.
3. Application of these Regulations.
4. Significant wave heights.
5. Classification of sea areas.
6. Stability requirements.
7. Certification.
8. Seasonal and short-time period operation.
9. Penalties.

SCHEDULE 1
SPECIFIC STABILITY REQUIREMENTS FOR
RO-RO PASSENGERS SHIPS

SCHEDULE 2
INDICATIVE GUIDELINES TO NATIONAL ADMINISTRATIONS

Gibraltar Merchant Shipping (Safety, etc.) **1995-13**

**Gibraltar Merchant Shipping (Stability Requirements for
Ro-Ro Passenger Ships) Regulations 2006** **2006/022**

In exercise of the powers conferred on it by section 118 of the Gibraltar Merchant Shipping (Safety, etc.) Act, 1993 and all other enabling powers, the Government has made the following Regulations:

Title and commencement.

1.(1) These Regulations may be cited as the Gibraltar Merchant Shipping (Stability Requirements for Ro-Ro Passenger Ships) Regulations 2006.

(2) These Regulations come into operation on a day to be appointed by the Minister with responsibility for the Port and Shipping by notice in the Gazette.

Interpretation.

2. In these Regulations, unless the context otherwise requires—

“Administration” means the Maritime Administrator in the case of Gibraltar, and in other cases the competent authorities of the State whose flag the ro-ro passenger ship is entitled to fly;

“Directive” means Directive 2003/25/EC of the European Parliament and of the Council of 14th April 2003 on specific stability requirements for ro-ro passenger ships as amended by Commission Directive 2005/12/EC of 18 February 2005;

“existing ship” means a ship which is not a new ship;

“Gibraltar waters” means the area of waters contained within the British territorial waters in Gibraltar;

“Gibraltar ro-ro passenger ship” means a ro-ro passenger ship or high speed craft registered in Gibraltar under the Gibraltar Merchant Shipping (Registration) Act, 1993;

“high speed craft” means a craft capable of a maximum speed in metres per second (m/s) equal to or exceeding: $3.7\nabla^{0.1667}$ where ∇ = volume of displacement corresponding to the design waterline (m³), excluding craft the hull of which is supported clear above the water surface in non displacement mode by aerodynamic forces generated by ground effect;

“international voyage” means a voyage between—

- (a) the port of Gibraltar and a port outside Gibraltar; or

1995-13 Gibraltar Merchant Shipping (Safety, etc.)

2006/022 Gibraltar Merchant Shipping (Stability Requirements for Ro-Ro Passenger Ships) Regulations 2006

(b) a port in another country and a port in any other country or territory which is outside Gibraltar;

“Maritime Administrator” means the person appointed under section 3 of the Act;

“new ship” means a ship the keel of which is laid or which is at a similar stage of construction on or after 1st October 2004,

“Non-Gibraltar ro-ro passenger ship” means a ro-ro passenger ship which is not a Gibraltar ro-ro passenger ship;

“passenger” means every person other than the master and the members of the crew or other persons employed or engaged in any capacity on board a ship on the business of that ship and other than a child under one year of age;

“regular service” means a series of ro-ro passenger ship crossings serving traffic between the same two or more ports, which is operated either—

(a) according to a published timetable; or

(b) with crossings so regular or frequent that they constitute a recognisable systematic series;

“ro-ro passenger ship” means a ship carrying more than 12 passengers, having ro-ro cargo spaces or special category spaces as defined in Regulation II-2/3 of the SOLAS Convention;

“significant wave height” is the average height of the highest third of wave heights observed over a given period;

“similar stage of construction” means the stage at which construction identifiable with a specific ship begins, and assembly of that ship has commenced comprising at least 50 tonnes or 1% of the estimated mass of structural material, whichever is less;

“SOLAS Convention” means the International Convention for the Safety of Life at Sea 1974 as amended in accordance with its Protocols of 1978 and 1988, in its up-to date version as in force at the time of reference;

“Stockholm Agreement” means the Agreement concluded at Stockholm on 27th and 28 February 1996 in pursuance of SOLAS 95 Conference Resolution 14, “Regional agreements on specific stability requirements for ro-ro passenger ships”, adopted on 29 November 1995.

Application of these Regulations.

3. These Regulations shall apply to—

- (a) a Gibraltar ro-ro passenger ship which operates to or from the port of Gibraltar or a port of an EEA State on a regular service on international voyages; and
- (b) a non-Gibraltar ro-ro passenger ship which operates to or from the Port of Gibraltar on a regular service to or from a port of an EEA State or on international voyages.

Significant wave heights.

4.(1) The significant wave heights (h_s) shall be used for determining the height of water on the car deck when applying the specific stability requirements specified in Schedule 1.

(2) The figures of significant wave heights shall be those that are not exceeded by a probability of more than 10 % on a yearly basis.

Classification of sea areas.

5.(1) The Maritime Administrator may, with the approval of the Minister, make and issue, in exercise of powers conferred on him by section 3(5) of the Act, from time to time, by notice in the Gazette, Administrative Instructions—

- (a) classifying and updating the list of sea areas within Gibraltar Waters; and
- (b) delimiting the zones for all-year-round and, where appropriate, restricted periodical operation of ro-ro passenger ships.

(2) The Administrative Instructions referred to in subregulation (1) may be amended, replaced or revoked by the Maritime Administrator in the same way as a new Instruction is made and issued by him.

(3) The Maritime Administrator shall, for the purpose of Article 5 of the Directive, cause the Administrative Instructions issued under subregulation (1) to be notified to the Commission.

Stability requirements.

6.(1) Subject to subregulations (2) and (4), a ro-ro passenger ship which is a new ship shall comply with the stability requirements as specified in Schedule 1, taking into account in such

1995-13 Gibraltar Merchant Shipping (Safety, etc.)

2006/022 Gibraltar Merchant Shipping (Stability Requirements for Ro-Ro Passenger Ships) Regulations 2006

compliance the guidelines set out in Schedule 2 in so far as this is practicable and compatible with the design of that ship.

(2) On and after 1st October 2010 a ro-ro passenger ship which is an existing ship, other than a ship which—

- (a) operates exclusively in one or more sea areas where the significant wave height is equal to or lower than 1.5 metres; or
- (b) on 17th May 2003 complied with the requirements of Regulation II-1/B8 of the SOLAS Convention,

shall comply with the stability requirements as specified in Schedule 1, taking into account in such compliance the guidelines set out in Schedule 2 in so far as this is practicable and compatible with the design of that ship.

(3) On and after 1st October 2015 a ro-ro passenger ship which is an existing ship, other than a ship—

- (a) which operates exclusively in one or more sea areas where the significant wave height is equal to or lower than 1.5 metres; or
- (b) to which subregulation (2) applies,

shall comply with the stability requirements as specified in the Schedule 1, taking into account in such compliance the guidelines set out in Schedule 2 in so far as this is practicable and compatible with the design of that ship.

(4) A ro-ro passenger ship that operates exclusively in one or more sea areas where the significant wave height is equal to or lower than 1.5 metres shall comply with the stability requirements of Regulation II-1/B/8 of the SOLAS Convention.

Certification.

7.(1) Subregulations (2) and (3) of this regulation do not apply to ro-ro passenger ships operating exclusively in sea areas where the significant wave height is equal to or lower than 1.5 metres.

(2) A Gibraltar ro-ro passenger ship to which regulation 3 applies shall carry a certificate issued by the Administration in accordance with the guidelines set out in Schedule 2 (in so far as those guidelines are practicable and compatible with the design of that ship), which—

- (a) confirms that the ship complies with the stability requirements of regulation 6; and
 - (b) indicates the highest value of significant wave height up to which the ship satisfies the requirements of regulation 6.
- (3) A non-Gibraltar ro-ro passenger ship to which the requirements of regulation 6 apply shall carry a certificate issued by the Administration of the third country whose flag it flies which—
- (a) confirms that the ship complies with the stability requirements of regulation 6; and
 - (b) indicates the highest value of significant wave height up to which the ship satisfies the requirements of regulation 6.
- (4) A ro-ro passenger ship or high speed craft shall not operate in a sea area in Gibraltar waters with a higher value of significant wave height than that shown on its certificate.

Seasonal and short-time period operation.

8.(1) Where the operator of a regular service which operates throughout the year wishes to introduce an additional ro-ro passenger ship or high speed craft onto that service for a period of less than one year, that operator shall give the Administration at least one month's notice of the proposed operation of the additional ship or craft.

(2) If—

- (a) a replacement ro-ro passenger ship or high speed craft is being introduced onto a regular service which operates throughout the year following unforeseen circumstances and in order to ensure continuity of service; and
- (b) that replacement ro-ro passenger ship or high speed craft complies with the requirements of the Gibraltar Merchant Shipping (Ro-Ro Ferry and High-speed Passenger Craft on Regular Service) Regulations 2005,

regulation 6 and subregulation (1) above shall not apply to that ship or craft.

(3) The operator of a regular service which operates seasonally for a period not exceeding six months in a period of twelve months shall give the Administration three months' notice of the proposed operation of the service.

(4) Where a regular service which operates seasonally for a period not exceeding six months in a period of twelve months operates under conditions of lower significant wave height than

1995-13 Gibraltar Merchant Shipping (Safety, etc.)

2006/022 Gibraltar Merchant Shipping (Stability Requirements for
Ro-Ro Passenger Ships) Regulations 2006

those established for year round operation by Schedule 1, the significant wave height value applicable for this shorter time period may be used for determining the height of water on the deck when applying regulation 4 and the specific stability requirements contained in Schedule 1.

Penalties.

9.(1) Any contravention of regulation 6 or 7 of these Regulations in respect of a ro-ro passenger ship or high speed craft shall be an offence by both the owner and the master of that ship and shall be punishable, on summary conviction, by a fine not exceeding level 5 on the standard scale or on conviction on indictment by imprisonment for a term not exceeding two years, or a fine, or both.

(2) Any contravention of regulation 8(1) or (3) of these Regulations by the operator of a regular service shall be an offence by that operator which is punishable, on summary conviction, by a fine not exceeding level 4 on the standard scale or on conviction on indictment by imprisonment for a term not exceeding two years, or a fine, or both.

(3) It shall be a defence for a person charged under these Regulations to show that he took all reasonable steps to avoid the commission of the offence.

SCHEDULE 1

Regulations 6

SPECIFIC STABILITY REQUIREMENTS FOR RO-RO PASSENGERS SHIPS

1. In addition to the requirements of Regulation II-1/B/8 of the SOLAS Convention relating to watertight subdivision and stability in damaged condition, all ro-ro passenger ships to which these Regulations apply shall comply with the requirements of this Schedule.

2. The provisions of Regulation II-1/B/8.2.3 shall be complied with when taking into account the effect of a hypothetical amount of sea water which is assumed to have accumulated, on the first deck above the design waterline of the ro-ro cargo space or the special cargo space as defined in Regulation II-2/3 assumed to be damaged (hereinafter referred to as “the damaged ro-ro deck”). The other requirements of regulation II-1/B/8 need not be complied with in the application of the stability standard contained in this Schedule. The amount of assumed accumulated sea water shall be calculated on the basis of a water surface having a fixed height above:

- (a) the lowest point of the deck edge of the damaged compartment of the ro-ro deck; or
- (b) when the deck edge in way of the damaged compartment is submerged then the calculation is based on a fixed height above the still water surface at all heel and trim angles;

as follows:

- (i) 0.5 m if the residual freeboard (f_r) is 0.3 m or less;
- (ii) 0.0 m if the residual freeboard (f_r) is 2.0 m or more; and

intermediate values to be determined by linear interpolation, if the residual freeboard (f_r) is 0.3 m or more but less than 2.0 m;

where the residual freeboard (f_r) is the minimum distance between the damaged ro-ro deck and the final waterline at the location of the damage in the damage case being considered without taking into account the effect of the volume of assumed accumulated water on the damaged ro-ro deck;

3. When a high-efficiency drainage system is installed, the Administration may allow a reduction in the height of the water surface.

1995-13 Gibraltar Merchant Shipping (Safety, etc.)

2006/022 Gibraltar Merchant Shipping (Stability Requirements for
Ro-Ro Passenger Ships) Regulations 2006

4. For ships in geographically defined restricted areas of operation, the Administration may reduce the height of the water surface prescribed in accordance with paragraph 2 by substituting such height of the water surface by the following–

- (a) 0.0 m if the significant wave height (h_s) defining the area concerned is 1.5 m or less;
- (b) the value determined in accordance with paragraph 2 if the significant wave height (h_s) defining the area concerned is 4.0 m or above;
- (c) intermediate values to be determined by linear interpolation if the significant wave height (h_s) defining the area concerned is 1.5m or more but less than 4.0 m,

Provided that the following conditions are fulfilled–

- (i) the Administration is satisfied that the defined area is represented by the significant wave height (h_s) which is not exceeded with a probability of more than 10%; and
- (ii) the area of operation and, if applicable, the part of the year for which a certain value of the significant wave height (h_s) has been established are entered on the certificates.

5. As an alternative to the requirements of paragraph 2 or paragraph 4, the Administration may exempt application of the requirements of paragraph 2 or paragraph 4 and accept proof, established by model tests carried out for an individual ship in accordance with the model test method which appears in the Appendix to this Schedule, justifying that the ship will not capsize with the assumed extent of damage as provided in Regulation II-1/B/8.24 in the worst location being considered under paragraph 2 in an irregular seaway; and reference to acceptance of the results of the model test as an equivalence to compliance with paragraph 2 or paragraph 4 and the value of the significant wave height (h_s) used in the model tests shall be entered into the ship's certificates.

6. The information supplied to the master in accordance with Regulation II-1/B/8.7.1 and Regulation II-1/B/8.7.2, as developed for compliance with Regulations II-1/B/8.2.3 to II-1/B/8.2.3.4, shall apply unchanged for ro-ro passenger ships approved according to these requirements.

7. For assessing the effect of the volume of the assumed accumulated sea water on the damaged ro-ro deck in paragraph 1, the following provisions shall prevail–

- (a) a transverse or longitudinal bulkhead shall be considered intact if all parts of it lie inboard of vertical surfaces on both sides of the ship, which are situated at a distance from the shell plating equal to one-fifth of the breadth of the ship, as defined in Regulation II-1/2, and measured at right angles to the centreline at the level of the deepest subdivision load line;
- (b) in cases where the ship's hull is structurally partly widened for compliance with the provisions of this Schedule, the resulting increase of the value of one-fifth of the breadth of it is to be used throughout, but shall not govern the location of existing bulkhead penetrations, piping systems, etc, which were acceptable prior to the widening;
- (c) the tightness of transverse or longitudinal bulkheads which are taken into account as effective to confine the assumed accumulated sea water in the compartment concerned in the damaged ro-ro deck shall be commensurate with the drainage system, and shall withstand hydro-static pressure in accordance with the results of the damage calculation. Such bulkheads shall be at least 4 m in height unless the height of water is less than 0,5m. In such cases the height of the bulkhead may be calculated in accordance with the following—

$$Bh = 8hw$$

where:

Bh is the bulkhead height;
and hw is the height of water.

In any event, the minimum height of the bulkhead should be not less than 2.2m. However, in case of a ship with hanging car decks, the minimum height of the bulkhead shall be not less than the height to the underside of the hanging deck when in its lowered position;

- (d) for special arrangements such as e.g., full-width hanging decks and wide side casings, other bulkhead heights may be accepted based on detailed model tests;
- (e) the effect of the volume of the assumed accumulated sea water need not be taken into account for any compartment of the damaged ro-ro deck, provided that such a compartment has on each side of the deck freeing ports evenly distributed along the sides of the compartment complying with the following:

(i) $A \geq 0.3 I$

1995-13 Gibraltar Merchant Shipping (Safety, etc.)

2006/022 Gibraltar Merchant Shipping (Stability Requirements for
Ro-Ro Passenger Ships) Regulations 2006

where A is the total area of freeing ports on each side of the deck in m²; and I is the length of the compartment in m;

- (ii) the ship shall maintain a residual freeboard of at least 1.0 m in the worst damage condition without taking into account the effect of the assumed volume of water on the damaged ro-ro deck; and
- (iii) such freeing ports shall be located within the height of 0.6 m above the damaged ro-ro deck, and the lower edge of the ports shall be within 2 cm above the damaged ro-ro deck; and
- (iv) such freeing ports shall be fitted with closing devices or flaps to prevent water entering the ro-ro deck whilst allowing water which may accumulate on the ro-ro deck to drain.

8. When a bulkhead above the ro-ro deck is assumed damaged, both compartments bordering the bulkhead shall be assumed flooded to the same height of water surface as calculated in paragraph 2 or 4 above.

9. When determining significant wave height, the wave heights given on the maps or list of sea areas established by Member States in line with Article 5 of the Directive, shall be used.

10. For ships which are to be operated only for a shorter season, the Administration as a host Administration shall determine in agreement with the other country whose port is included in the ships route, the significant wave height to be used.

11. Model tests shall be conducted in accordance with the APPENDIX annexed hereto.

APPENDIX TO SCHEDULE 1

Model test method

1. Objectives.

This revised model test method is a revision of the method contained in the Appendix to the Annex to resolution 14 of the 1995 SOLAS Conference. Since the entry into force of the Stockholm Agreement a number of model tests has been carried out in accordance with the test method previously in force. During these tests a number of refinements in the procedures have been identified. This new model test method aims to include these refinements and, together with the appended Guidance Notes, provide a more robust procedure for the assessment of survivability of a damaged ro-ro passenger ship in a seaway. In the tests

provided for in paragraph 1.4 of the stability requirements included in Annex I, the ship should be capable of withstanding a seaway as defined in paragraph 4 hereunder in the worst-damage-case scenario.

2. Definitions.

LBP is the length between perpendiculars

Hs is the significant wave height

B is the moulded breadth of the ship

T_p is the peak period

T_z is the zero crossing period

3. Ship model.

3.1. The model should copy the actual ship for both outer configuration and internal arrangement, in particular all damaged spaces having an effect on the process of flooding and shipping of water. Intact draught, trim, heel and limiting operational KG corresponding to the worst damage case should be used. Furthermore, the test case(s) to be considered should represent the worst damage case(s) defined in accordance with SOLAS regulation II-1/8.2.3.2 (SOLAS 90) with regard to the total area under the positive GZ curve and the centreline of the damage opening should be located within the following range:

3.1.1. $\pm 35\%$ LBP from midship;

3.1.2. an additional test will be required for the worst damage within $\pm 10\%$ LBP from midship if the damage case referred to in .1 is outside of $\pm 10\%$ LBP from midship.

3.2. The model should comply with the following:

3.2.1. length between perpendiculars (LBP) is to be at least 3 m or a length corresponding to a model scale of 1:40, whichever is greater, and the vertical extent up to at least three superstructure standard heights above the bulkhead (freeboard) deck;

3.2.2. hull thickness of flooded spaces should not exceed 4 mm;

3.2.3. in both intact and damaged conditions, the model should satisfy the correct displacement and draught marks (T_A, T_M, T_F, port and starboard) with a maximum

1995-13 Gibraltar Merchant Shipping (Safety, etc.)

2006/022 Gibraltar Merchant Shipping (Stability Requirements for Ro-Ro Passenger Ships) Regulations 2006

tolerance in any one draught mark of + 2 mm. Draught marks forward and aft should be located as near FP and AP as practicable;

3.2.4. all damaged compartments and ro-ro spaces should be modelled with the correct surface and volume permeabilities (actual values and distributions) ensuring that floodwater mass and mass distribution are correctly represented;

3.2.5. the characteristics of motion of the actual ship should be modelled properly, paying particular attention to the intact GM tolerance and radii of gyration in roll and pitch motion. Both radii should be measured in air and be in the range of 0.35B to 0.4B for roll motion, and 0.2LOA to 0.25LOA for pitch motion;

3.2.6. main design features such as watertight bulkheads, air escapes, etc., above and below the bulkhead deck that can result in asymmetric flooding should be modelled properly as far as practicable to represent the real situation; Ventilating and cross-flooding arrangements should be constructed to a minimum cross section of 500 mm²;

3.2.7. the shape of the damage opening should be as follows:

1. trapezoidal profile with side at 15° slope to the vertical and the width at the design waterline defined according to SOLAS regulation II-1/8.4.1;
2. isosceles triangular profile in the horizontal plane with the height equal to B/5 according to SOLAS regulation II-1/8.4.2. If side casings are fitted within B/5, the damaged length in way of the side casings should not be less than 25 mm;
3. notwithstanding the provisions of subparagraphs 3.2.7.1 and 3.2.7.2 above, all compartments taken as damaged in calculating the worst damage case(s) referred to in paragraph 3.1 should be flooded in the model tests;

3.3. The model in the flooded equilibrium condition should be heeled by an additional angle corresponding to that induced by the heeling moment $M_h = \max(M_{\text{pass}}; M_{\text{launch}}) - M_{\text{wind}}$, but in no case should the final heel be less than 1° towards damage. M_{pass} , M_{launch} and M_{wind} are as specified in SOLAS regulation II-1/8.2.3.4. For existing ships this angle may be taken as 1°.

4. Procedure for experiments.

4.1. The model should be tested in a long-crested irregular seaway defined by the JONSWAP spectrum with significant wave height H_S , a peak enhancement factor $\gamma = 3.3$ and a peak period

$T_P = 4\sqrt{H_s}$ ($T_Z = T_P/1.285$). H_s is the significant wave height for the area of operation, which is not exceeded by a probability of more than 10 % on a yearly basis, but limited to a maximum of 4 m.

Furthermore,

- 4.1.1. the basin width should be sufficient to avoid contact or other interaction with the sides of the basin and is recommended not to be less than $L_{BP}+2m$;
 - 4.1.2. the basin depth should be sufficient for proper wave modelling but should not be less than 1m;
 - 4.1.3. for a representative wave realisation to be used, measurements should be performed prior to the test at three different locations within the drift range;
 - 4.1.4. the wave probe closer to the wave maker should be located at the position where the model is placed when the test starts;
 - 4.1.5. variation in H_s and T_P should be within $\pm 5\%$ for the three locations; and
 - 4.1.6. during the tests, for approval purposes, a tolerance of $+ 2.5\%$ in H_s , $\pm 2.5\%$ in T_P and $\pm 5\%$ in T_Z should be allowed with reference to the probe closer to the wave maker.
- 4.2. The model should be free to drift and placed in beam seas (90° heading) with the damage hole facing the oncoming waves, with no mooring system permanently attached to the model used. To maintain a beam sea heading of approximately 90° during the model test the following requirements should be satisfied:
- 4.2.1. heading control lines, intended for minor adjustment, should be located at the centre line of the stem and stern, in a symmetrical fashion and at a level between the position of KG and the damaged waterline; and
 - 4.2.2. the carriage speed should be equal to the actual drift speed of the model with speed adjustment made when necessary.
- 4.3. At least 10 experiments should be carried out. The test period for each experiment should be of a duration such that a stationary state is reached, but not less than 30 min in full-scale. A different wave realisation train should be used for each experiment.

5. Survival criteria.

1995-13 Gibraltar Merchant Shipping (Safety, etc.)

2006/022 Gibraltar Merchant Shipping (Stability Requirements for
Ro-Ro Passenger Ships) Regulations 2006

The model should be considered as surviving if a stationary state is reached for the successive test runs as required in paragraph 4.3. The model should be considered as capsized if angles of roll of more than 30° to the vertical axis or steady (average) heel greater than 20° for a period longer than three minutes full-scale occur, even if a stationary state is reached.

6. Test documentation.

6.1. The model test programme should be approved by the Administration in advance.

6.2. Tests should be documented by means of a report and a video or other visual records containing all relevant information on the model and the test results, which are to be approved by the Administration. These should include, as a minimum, the theoretical and measured wave spectra and statistics (Hs, Tp, Tz) of the wave elevation at the three different locations in the basin for a representative realisation, and for the tests with the model, the time series of main statistics of the measured wave elevation close to the wave maker and records of model roll, heave and pitch motions, and of the drift speed.'

SCHEDULE 2

Regulations 6 and 7

INDICATIVE GUIDELINES TO NATIONAL ADMINISTRATIONS**PART I
APPLICATION**

In line with the relevant provisions of regulation 6, these guidelines shall be used by the Administrations in the application of the specific stability requirements specified in Schedule 1, in so far as this is practicable and compatible with the design of the ship in question. The paragraph numbers appearing below correspond to those in Schedule 1.

Paragraph 1

As a first step all ro-ro passenger ships to which these Regulations apply must comply with the SOLAS 90 standard of residual stability as it applies to all passenger ships constructed on or after 29 April 1990. It is the application of this requirement that defines the residual freeboard fr , necessary for the calculations required in paragraph 2.

Paragraph 2

1. This paragraph addresses the application of a hypothetical amount of water accumulated on the bulkhead (ro-ro) deck. The water is assumed to have entered the deck via a damage opening. This paragraph requires that the ship in addition to complying with the full requirements of the SOLAS 90 standard further complies with that part of the SOLAS 90 criteria contained in points 2.3 to 2.3.4 of Regulation II-1/B/8 with the defined amount of water on deck. For this calculation no other requirements of Regulation II-1/B/8 need be taken into account. For example the ship does not, for this calculation, need to comply with the requirements for the angles of equilibrium or non-submergence of the margin line.

2. The accumulated water is added as a liquid load with one common surface inside all compartments which are assumed flooded on the car deck. The height (h_w) of water on deck is dependent on the residual freeboard (fr) after damage, and is measured in way of the damage (see figure 1). The residual freeboard, is the minimum distance between the damaged ro-ro deck and the final waterline (after equalisation measures if any have been taken) in way of the assumed damage after examining all possible damage scenarios in determining the compliance with the SOLAS 90 standard as required in paragraph 1 Schedule 1. No account should be taken of the effect of the hypothetical volume of water assumed to have accumulated on the damaged ro-ro deck when calculating fr .

1995-13 Gibraltar Merchant Shipping (Safety, etc.)

2006/022 Gibraltar Merchant Shipping (Stability Requirements for Ro-Ro Passenger Ships) Regulations 2006

3. If fr is 2.0 m or more, no water is assumed to accumulate on the ro-ro deck. If fr is 0.3 m or less, then height h_w is assumed to be 0.5 m. Intermediate heights of water are obtained by linear interpolation (see figure 2).

Paragraph 3

Means for drainage of water can only be considered as effective if these means are of a capacity to prevent large amounts of water from accumulating on the deck i.e. many thousands of tonnes per hour which is far beyond the capacities fitted at the time of the adoption of these regulations. Such high efficiency drainage systems may be developed and approved in the future (based on guidelines to be developed by the International Maritime Organisation).

Paragraph 4

1. The amount of assumed accumulated water on deck may, in addition to any reduction in accordance with paragraph 2, be reduced for operations in geographically defined restricted areas. These areas are designated in accordance with the significant wave height (h_s) defining the area in line with the provisions of regulation 5 of these Regulations.

2. If the significant wave height (h_s), in the area concerned, is 1.5 m or less then no additional water is assumed to accumulate on the damaged ro-ro deck. If the significant wave height in the area concerned is 4.0 m or more then the height of the assumed accumulated water shall be the value calculated in accordance with paragraph 2. Intermediate values to be determined by linear interpolation (see figure 3).

3. The height h_w is kept constant, therefore the amount of added water is variable as it is dependent upon the heeling angle and whether at any particular heeling angle the deck edge is immersed or not (see figure 4). It should be noted that the assumed permeability of the car deck spaces is to be taken as 90 % (MSC/Circ.649 refers), whereas other assumed flooded spaces permeabilities are to be those prescribed in the SOLAS Convention.

4. If the calculations to demonstrate compliance with these Regulations relate to a significant wave height less than 4.0 m that restricting significant wave height must be recorded on the vessel's passenger ship safety certificate.

Paragraph 5

As an alternative to complying with the new stability requirements in paragraph 2 or 4, the Administration may accept proof of compliance via model tests. The model test requirements are detailed in the Appendix to Schedule 1. Guidance notes on the model tests are contained in part II of this Schedule.

Paragraph 6

Conventionally derived SOLAS 90 standard limiting operational curve(s) (KG or GM) may not remain applicable in cases where 'water on deck' is assumed under the terms of these Regulations and it may be necessary to determine revised limiting curve(s) which take into account the effects of this added water. To this effect sufficient calculations corresponding to an adequate number of operational draughts and trims must be carried out.

Note : Revised limiting operational KG/GM Curves may be derived by iteration, whereby the minimum excess GM resulting from damage stability calculations with water on deck is added to the input KG (or deducted from the GM) used to determine the damaged freeboards (fr), upon which the quantities of water on deck are based, this process being repeated until the excess GM becomes negligible.

It is anticipated that operators would begin such an iteration with the maximum KG/minimum GM which could reasonably be sustained in service and would seek to manipulate the resulting deck bulkhead arrangement to minimise the excess GM derived from damage stability calculations with water on deck.

Paragraph 7(a)

As for conventional SOLAS damage requirements bulkheads inboard of the B/5 line are considered intact in the event of side collision damage.

Paragraph 7(b)

If side structural sponsons are fitted to enable compliance with Regulation II-1/B/8, and as a consequence there is an increase in the breadth (B) of the ship and hence the vessel's B/5 distance from the ship's side, such modification shall not cause the relocation of any existing structural parts or any existing penetrations of the main transverse watertight bulkheads below the bulkhead deck (see figure 5).

Paragraph 7(c)

1. Transverse or longitudinal bulkheads/barriers which are fitted and taken into account to confine the movement of assumed accumulated water on the damaged ro-ro deck need not be strictly 'watertight'. Small amounts of leakage may be permitted subject to the drainage provisions being capable of preventing an accumulation of water on the 'other side' of the bulkhead/barrier. In such cases where scuppers become inoperative as a result of a loss of positive difference of water levels other means of passive drainage must be provided.

1995-13 Gibraltar Merchant Shipping (Safety, etc.)

2006/022 Gibraltar Merchant Shipping (Stability Requirements for Ro-Ro Passenger Ships) Regulations 2006

2. The height (B_h) of transverse and longitudinal bulkheads/barriers shall be not less than $(8 \times h_w)$ metres, where h_w is the height of the accumulated water as calculated by application of the residual freeboard and significant wave height (as referred to in paragraphs 2 and 4). However in no case is the height of the bulkhead/barrier to be less than the greater of—

- (a) 2.2 metres; or
- (b) the height between the bulkhead deck and the lower point of the underside structure of the intermediate or hanging car decks, when these are in their lowered position. It should be noted that any gaps between the top edge of the bulkhead and the underside of the plating must be ‘plated-in’ in the transverse or longitudinal direction as appropriate (see figure 6).

Bulkheads/barriers with a height less than that specified above, may be accepted if model tests are carried out in accordance with Part II of this Schedule to confirm that the alternative design ensures appropriate standard of survivability. Care needs to be taken when fixing the height of the bulkhead/barrier such that the height shall also be sufficient to prevent progressive flooding within the required stability range. This range is not to be prejudiced by model tests.

Note : The range may be reduced to 10 degrees provided the corresponding area under the curve is increased (as referred to in MSC 64/22).

Paragraph 7(e)(i)

The area ‘A’ relates to permanent openings. It should be noted that the ‘freeing ports’ option is not suitable for ships which require the buoyancy of the whole or part of the superstructure in order to meet the criteria. The requirement is that the freeing ports shall be fitted with closing flaps to prevent water entering, but allowing water to drain.

These flaps must not rely on active means. They must be self-operating and it must be shown that they do not restrict outflow to a significant degree. Any significant efficiency reduction must be compensated by the fitting of additional openings so that the required area is maintained.

Paragraph 7(e)(ii)

For the freeing ports to be considered effective the minimum distance from the lower edge of the freeing port to the damaged waterline shall be at least 1.0m. The calculation of the minimum distance shall not take into account the effect of any additional water on deck (see figure 7).

Paragraph 7(e)(iii)

Freeing ports must be sited as low as possible in the side bulwark or shell plating. The lower edge of the freeing port opening must be no higher than 2 cm above the bulkhead deck and the upper edge of the opening no higher than 0.6m (see figure 8).

Note : Spaces to which paragraph 7(e) applies, i.e. those spaces fitted with freeing ports or similar openings, shall not be included as intact spaces in the derivation of the intact and damage stability curves.

Paragraph 8

1. The statutory extent of damage is to be applied along the length of the ship. Depending on the subdivision standard the damage may not affect any bulkhead or may only affect a bulkhead below the bulkhead deck or only bulkhead above the bulkhead deck or various combinations.

2. All transverse and longitudinal bulkheads/barriers which constrain the assumed accumulated amount of water must be in place and secured at all times when the ship is at sea.

3. In those cases where the transverse bulkhead/barrier is damaged the accumulated water on deck shall have a common surface level on both sides of the damaged bulkhead/barrier at the height h_w (see figure 9).

PART II**MODEL TESTING**

The purpose of these guidelines is to ensure uniformity in the methods employed in the construction and verification of the model as well as in the undertaking and analyses of the model tests.

The contents of paragraphs 1 and 2 of the Appendix to Schedule 1 are considered self-explanatory.

Paragraph 3 — Ship model

3.1. The material of which the model is made is not important in itself, provided that the model both in the intact and damaged condition is sufficiently rigid to ensure that its hydrostatic properties are the same as those of the actual ship and also that the flexural response of the hull in waves is negligible.

1995-13 Gibraltar Merchant Shipping (Safety, etc.)

2006/022 Gibraltar Merchant Shipping (Stability Requirements for Ro-Ro Passenger Ships) Regulations 2006

It is also important to ensure that the damaged compartments are modelled as accurately as practicably possible to ensure that the correct volume of flood water is represented.

Since ingress of water (even small amounts) into the intact parts of the model will affect its behaviour, measures must be taken to ensure that this ingress does not occur.

In model tests involving worst SOLAS damages near the ship ends, it has been observed that progressive flooding was not possible because of the tendency of the water on deck to accumulate near the damage opening and hence flow out. As such models were able to survive very high sea states, while they capsized in lesser sea states with less onerous SOLAS damages, away from the ends, the limit $\pm 35\%$ was introduced to prevent this.

Extensive research carried out for the purpose of developing appropriate criteria for new vessels has clearly shown that in addition to the GM and freeboard being important parameters in the survivability of passenger ships, the area under the residual stability curve is also another major factor. Consequently in choosing the worst SOLAS damage for compliance with the requirement of paragraph 3.1 the worst damage is to be taken as that which gives the least area under the residual stability curve.

3.2. Model particulars

3.2.1. In recognising that scale effects play an important role in the behaviour of the model during tests, it is important to ensure that these effects are minimised as much as practically possible. The model should be as large as possible since details of damaged compartments are easier constructed in larger models and the scale effects are reduced. It is therefore required that the model length is not less than that corresponding to 1:40 scale or 3m, whichever is greater.

It has been found during tests that the vertical extent of the model can affect the results when tested dynamically. It is therefore required that the ship is modelled to at least three super structure standard heights above the bulkhead (freeboard) deck so that the large waves of the wave train do not break over the model.

3.2.2. The model in way of the assumed damages must be as thin as practically possible to ensure that the amount of flood water and its centre of gravity is adequately represented. The hull thickness should not exceed 4 mm. It is recognised that it may not be possible for the model hull and the elements of primary and secondary subdivision in way of the damage to be constructed with sufficient detail and due to these constructional limitations it may not be possible to calculate accurately the assumed permeability of the space.

3.2.3. It is important that not only the draughts in the intact condition are verified, but also that the draughts of the damaged model are accurately measured for correlation with those derived

from the damaged stability calculation. For practical reasons a tolerance of + 2 mm in any draught is accepted.

3.2.4. After measuring the damaged draughts it may be found necessary to make adjustments to the permeability of the damaged compartment by either introducing intact volumes or by adding weights. However it is also important to ensure that the centre of gravity of the flood water is accurately represented. In this case any adjustments made must err on the side of safety.

If the model is required to be fitted with barriers on deck and the barriers are less than the bulkhead height indicated below, the model is to be fitted with CCTV so that any “splashing over” and any accumulation of water on the undamaged area of the deck can be monitored. In this case a video recording of the event is to form part of the test records.

The height of transverse or longitudinal bulkheads which are taken into account as effective to confine the assumed accumulated sea water in the compartment concerned in the damaged ro-ro deck should be at least 4m in height unless the height of water is less than 0.5 m. In such cases the height of the bulkhead may be calculated in accordance with the following:

$$B_h = 8h_w$$

where B_h is the bulkhead height; and

h_w is the height of water.

In any event, the minimum height of the bulkhead should be not less than 2.2 m. However, in the case of a ship with hanging car decks, the minimum height of the bulkhead should be not less than the height to the underside of the hanging car deck when in its lowered position.

3.2.5. In order to ensure that the model motion characteristics represent those of the actual ship it is important that the model is both inclined and rolled in the intact condition so that the intact GM and the mass distribution are verified. The mass distribution should be measured in air. The transverse radius of gyration of the actual ship should be in the range 0.35B to 0.4B and the longitudinal radius of gyration should be in the range 0.2L to 0.25L.

Note: While inclining and rolling the model in the damaged condition may be accepted as a check for the purpose of verifying the residual stability curve, such tests should not be accepted in lieu of the intact tests.

3.2.6. It is assumed that the ventilators of the damage compartment of the actual ship are adequate for unhindered flooding and movement of the flood water. However in trying to scale down the ventilating arrangements of the actual ship undesirable scale effects may be

1995-13 Gibraltar Merchant Shipping (Safety, etc.)

2006/022 Gibraltar Merchant Shipping (Stability Requirements for Ro-Ro Passenger Ships) Regulations 2006

introduced in the model. In order to ensure that no such effects occur it is recommended to construct the ventilating arrangements to a larger scale than that of the model, ensuring that this does not affect the flow of water on the car deck.

3.2.7. It is deemed appropriate to consider a damage shape representative of a cross section of the striking ship in the bow region. The 15° angle is based on a study of the cross section at a distance of $B/5$ from the bow for a representative selection of vessels of different types and sizes.

The isosceles triangular profile of the prismatic damage shape is that corresponding to the load waterline. Additionally in cases where side casings of width less than $B/5$ are fitted and in order to avoid any possible scale effects, the damage length in way of the side casings must not be less than 25mm.

3.3. In the original model test method of resolution 14 of the 1995 SOLAS Conference the effect of heeling induced by the maximum moment deriving from any of passenger crowding, launching of survival craft, wind and turning was not considered even though this effect was part of SOLAS. Results from an investigation have shown, however, that it would be prudent to take these effects into account and to retain the minimum of 1° heel towards the damage for practical purposes. It is to be noted that heeling due to turning was considered not to be relevant.

3.4. In cases where there is a margin in GM in the actual loading conditions compared to the GM limiting curve (derived from SOLAS 90), the Administration may accept that this margin is taken advantage of in the model test. In such cases the GM limiting curve should be adjusted. This adjustment can be done as follows:

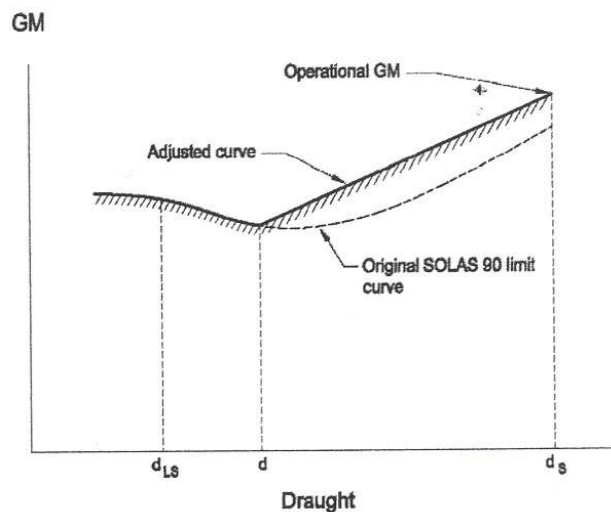

$$d = d_s - 0.6 (d_s - d_{LS})$$

where: d_s is the subdivision draught; and d_{LS} is the lightship draught.

The adjusted curve is a straight line between the GM used in the model test at the subdivision draught and the intersection of the original SOLAS 90 curve and draught d .

Paragraph 4 — Procedure for experiments

4.1. Wave spectra

The JONSWAP spectrum should be used as this describes fetch- and duration- limited seas which correspond to the majority of conditions world wide. In this respect it is important that not only the peak period of the wave train is verified but also that the zero crossing period is correct.

It is required that for every test run the wave spectrum is recorded and documented. Measurements for this recording should be taken at the probe closest to the wave making machine.

It is also required that the model is instrumented so that its motions (roll, heave and pitch) as well as its attitude (heel, sinkage and trim) are monitored and recorded through-out the test.

It has been found that it is not practical to set absolute limits for significant wave heights, peak periods and zero crossing periods of the model wave spectra. An acceptable margin has therefore been introduced.

4.2. To avoid interference of the mooring system with the ship dynamics, the towing carriage (to which the mooring system is attached) should follow the model at its actual drifting speed. In a sea state with irregular waves the drift speed will not be constant; a constant carriage speed would result in low frequency, large amplitude drift oscillations, which may affect the model behaviour.

4.3. A sufficient number of tests in different wave trains is necessary to ensure statistical reliability, i.e. the objective is to determine with a high degree of confidence that an unsafe ship will capsize in the selected conditions. A minimum number of 10 runs is considered to provide a reasonable level of reliability.

Paragraph 5 — Survival criteria

The contents of this paragraph are self-explanatory.

1995-13 Gibraltar Merchant Shipping (Safety, etc.)
2006/022 Gibraltar Merchant Shipping (Stability Requirements for
Ro-Ro Passenger Ships) Regulations 2006

Paragraph 6 — Test approval

The following documents are to be part of the report to the administration:

- (a) damage stability calculations for worst SOLAS and mid-ship damage (if different);
- (b) general arrangement drawing of the model together with details of construction and instrumentation;
- (c) inclining experiment and measurements of radii of gyration;
- (d) nominal and measured wave spectra (at the three different locations for a representative realisation and for the tests with the model from the probe closest to the wave maker);
- (e) representative record of model motions, attitude and drift;
- (f) relevant video recordings.

Note:

All tests must be witnessed by the administration.'

Figures

(Indicative guidelines to the Administration)

Figure 1

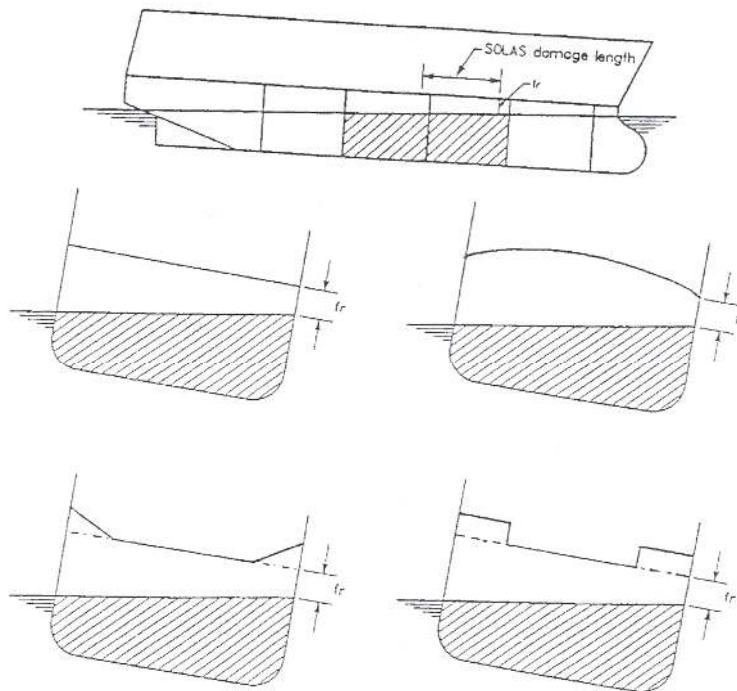
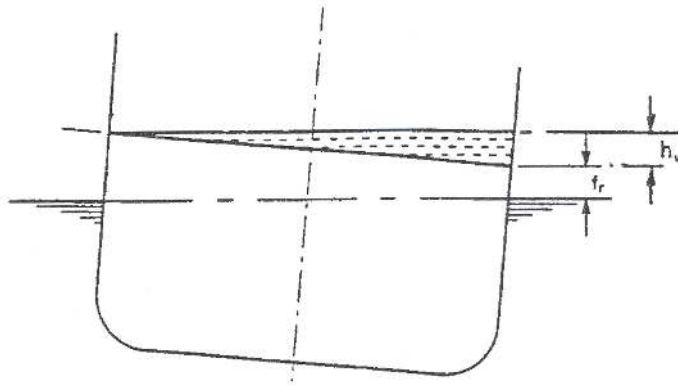
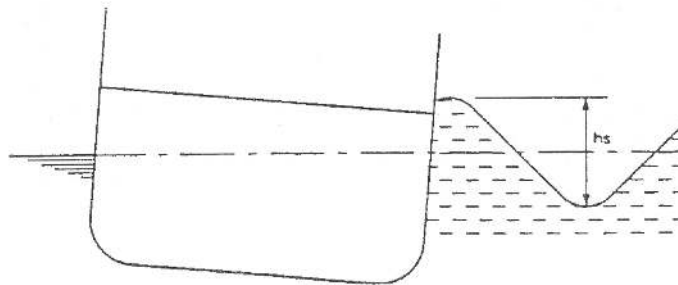

Figure 2



1. If $f_r \geq 2.0$ metres, height of water on deck (h_w) = 0.0 metres.
2. If $f_r < 0.3$ metres, height of water on deck (h_w) = 0.5 metres.

Figure 3



1. If $h_s \geq 4.0$ metres, height of water on deck is calculated as per figure 3.
2. If $h_s < 1.5$ metres, height of water on deck (h_w) = 0.0 metres.

For example:

If $f_r = 1.15$ metres and $h_s = 2.75$ metres, height $h_w = 0.125$ metres.

Figure 4

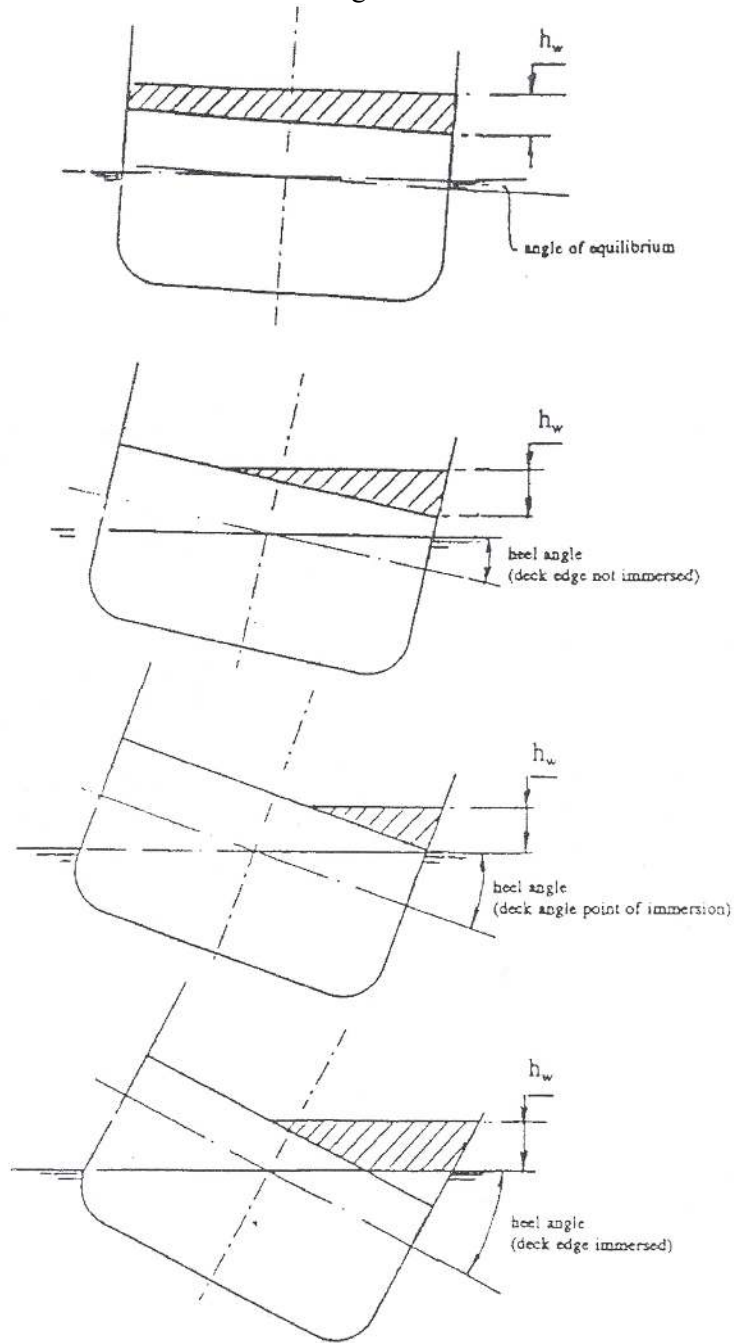

Figure 5

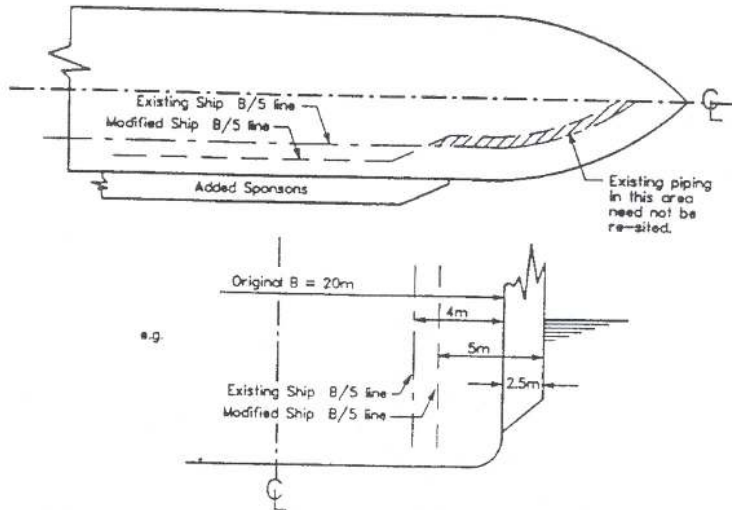
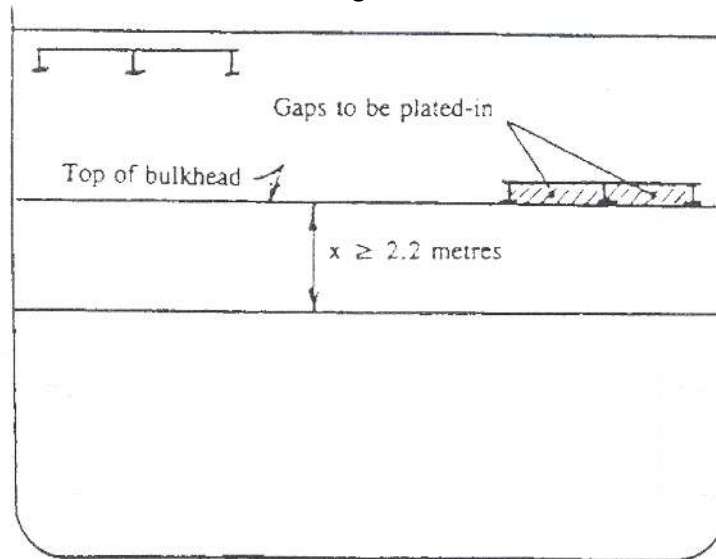

Figure 6



Ship without hanging car decks

Example 1:

Height of water on deck = 0,25 metres

Minimum required height of barrier = 2,2 metres

Ship with hanging deck (in way of the barrier)

Example 2:

Height of water on deck (hw) = 0,25 metres

Minimum required height of barrier = x

Figure 7

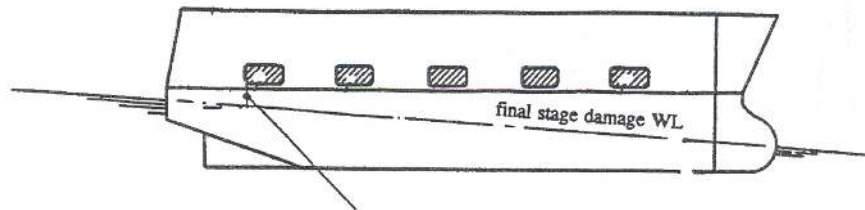

Minimum required freeboard to freeing port = 1,0 m

Figure 8

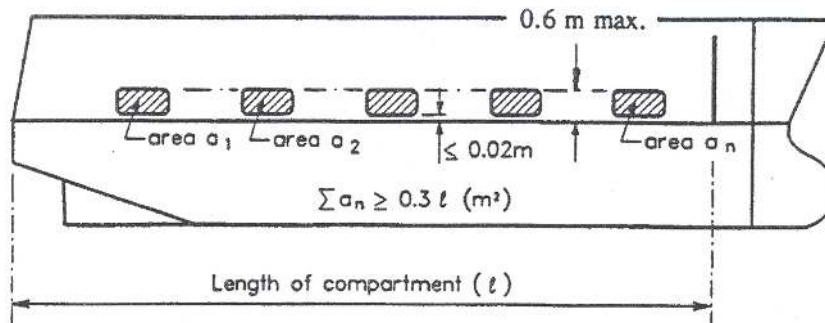
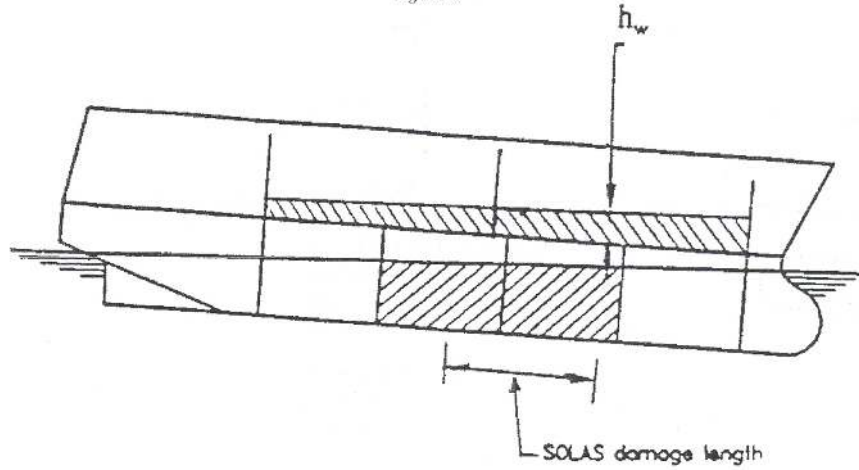
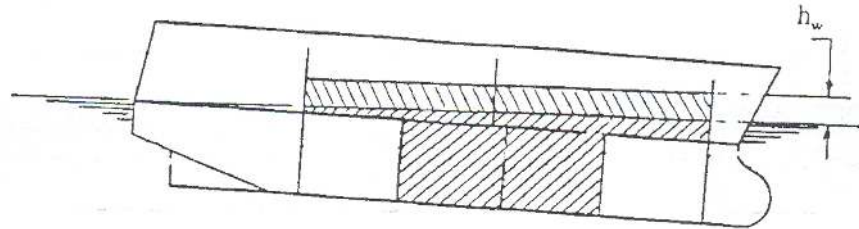

Figure 9



Deck edge not immersed



Deck edge immersed